



SAM PuttLab

The revolution in short game golf training

Project: Bay Of Plenty Golf
Player: Smith, Mark
File: 3rd measurement report Oct 06
Date: 14.10.2006



Face at address

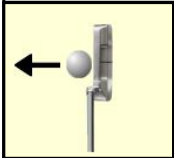
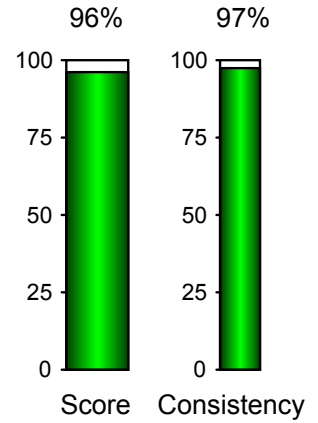
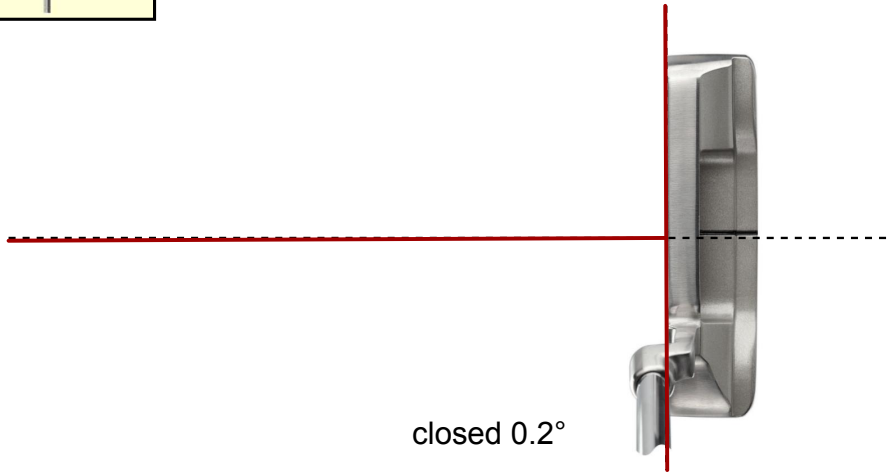

Face at impact

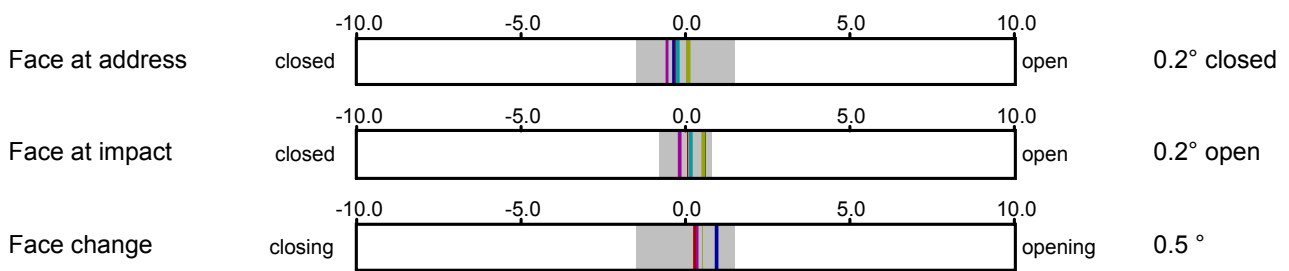
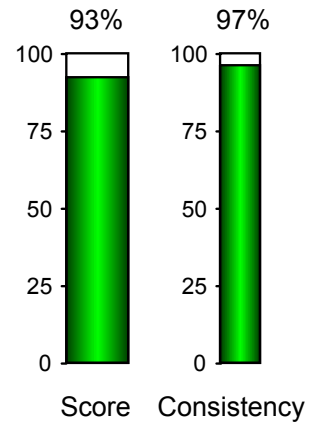
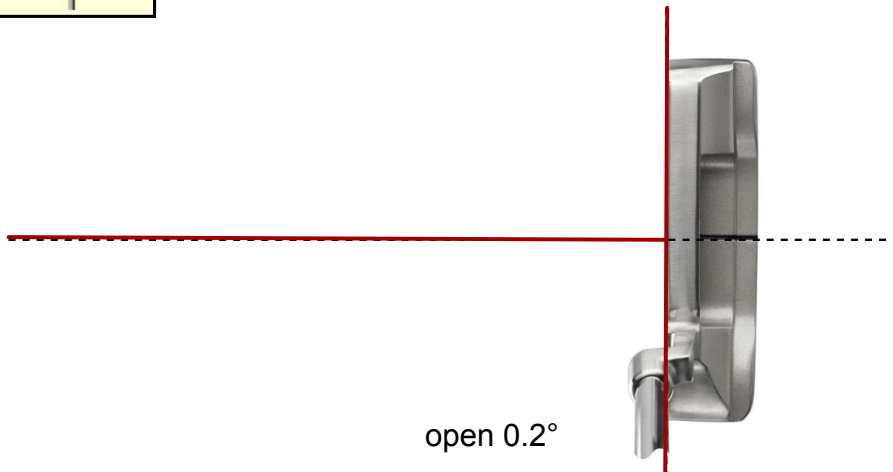



SAM PuttLab

The revolution in short game golf training

Project: Bay Of Plenty Golf
Player: Smith, Mark
File: 3rd measurement report Oct 06
Date: 14.10.2006

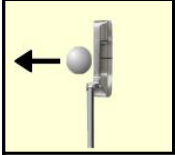

Putter path - top view

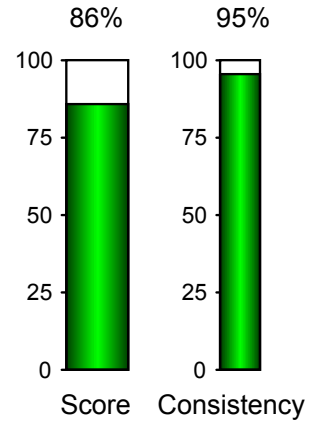
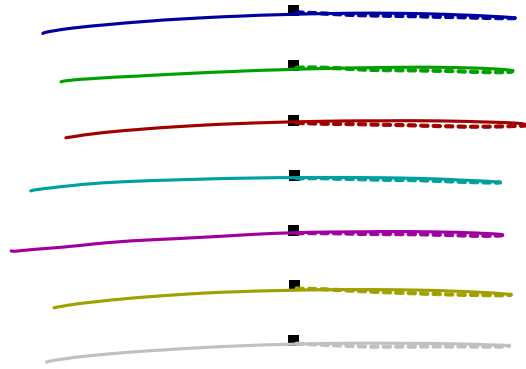

1.2° left at impact

Impact spot

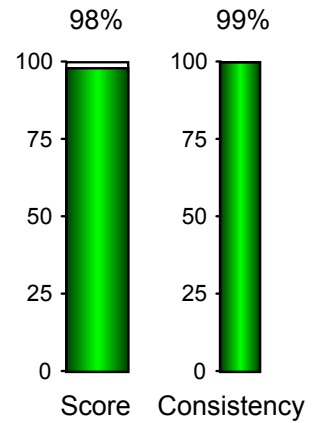
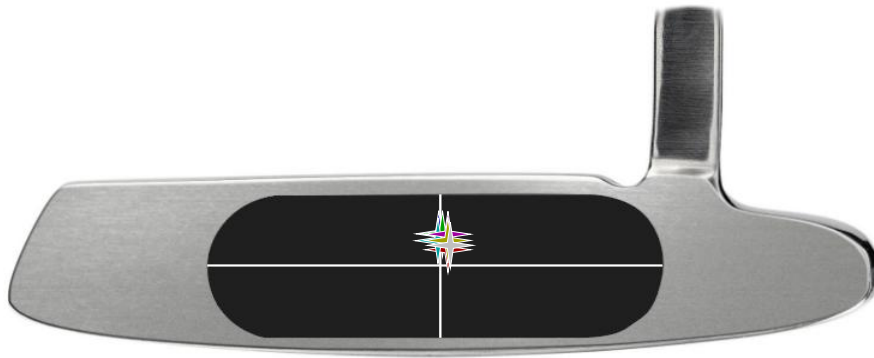

0.3 mm heel

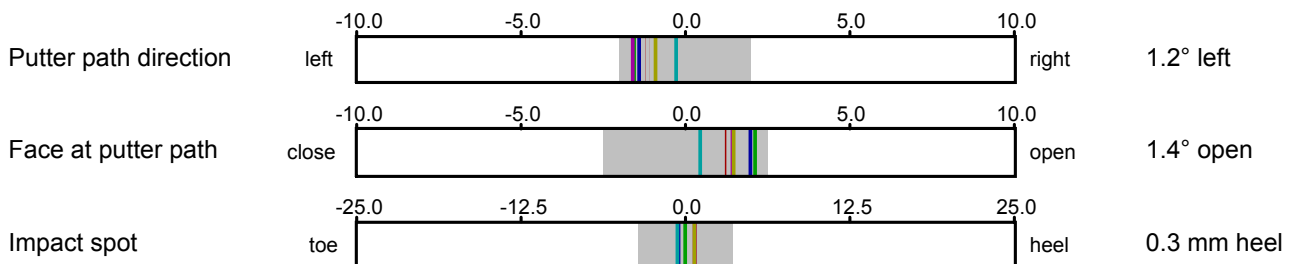



SAM PuttLab

The revolution in short game golf training

Project: Bay Of Plenty Golf
Player: Smith, Mark
File: 3rd measurement report Oct 06
Date: 14.10.2006

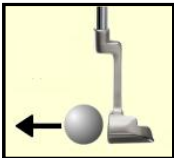

Putter path - side view

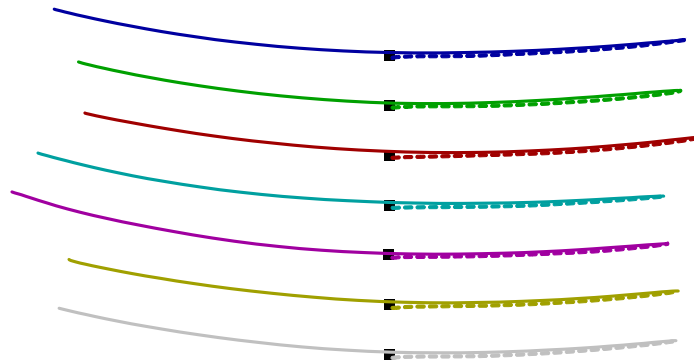

100 mm

2.2° up at impact

Rise & Shaft at impact

Rise angle: 2.2° up

Shaft angle: 0.5° deloft

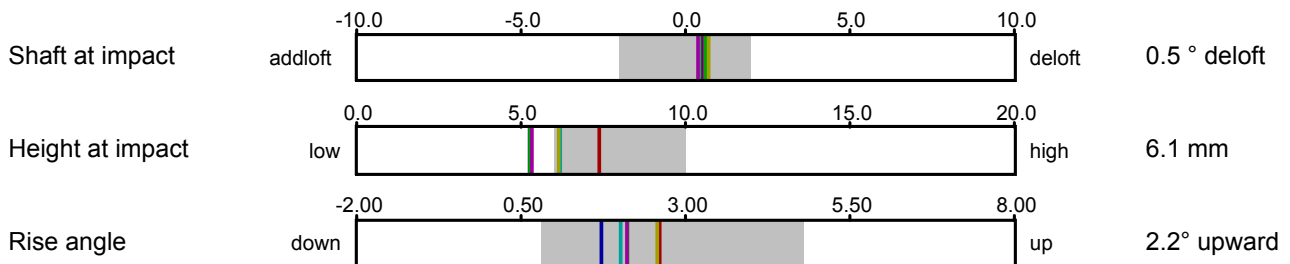
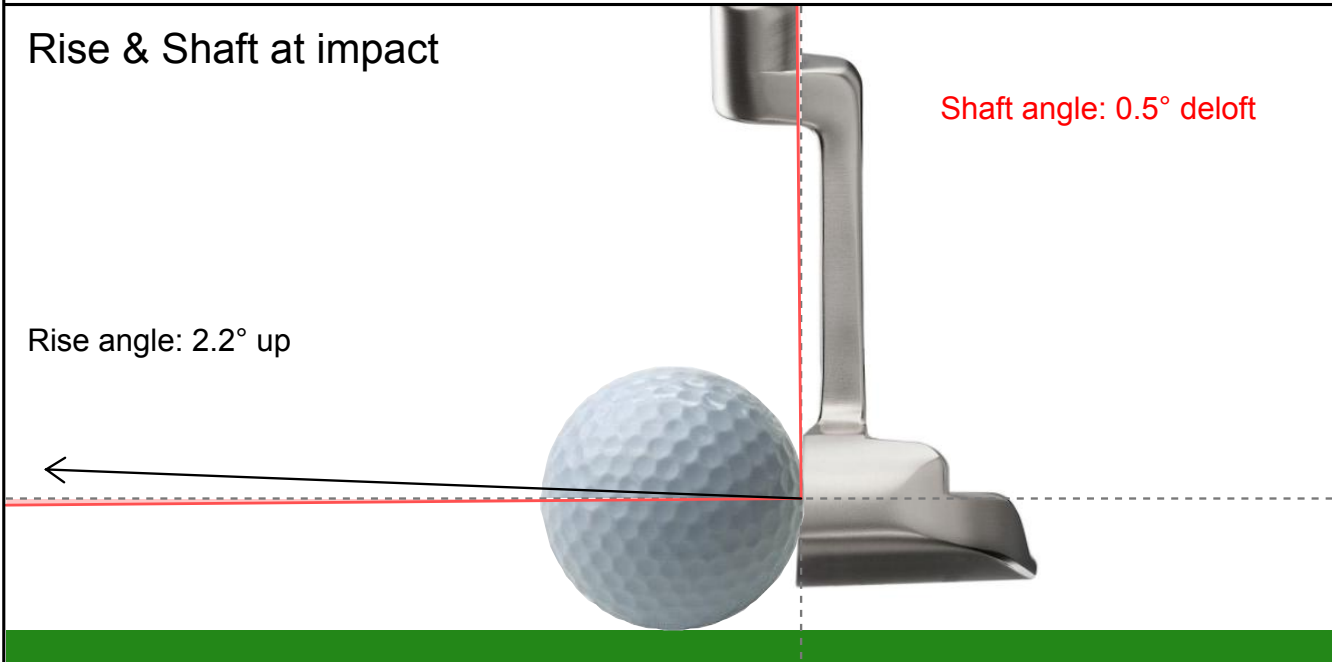



Project: Bay Of Plenty Golf
Player: Smith, Mark
File: 3rd measurement report Oct 06
Date: 14.10.2006

Clubhead Rotation

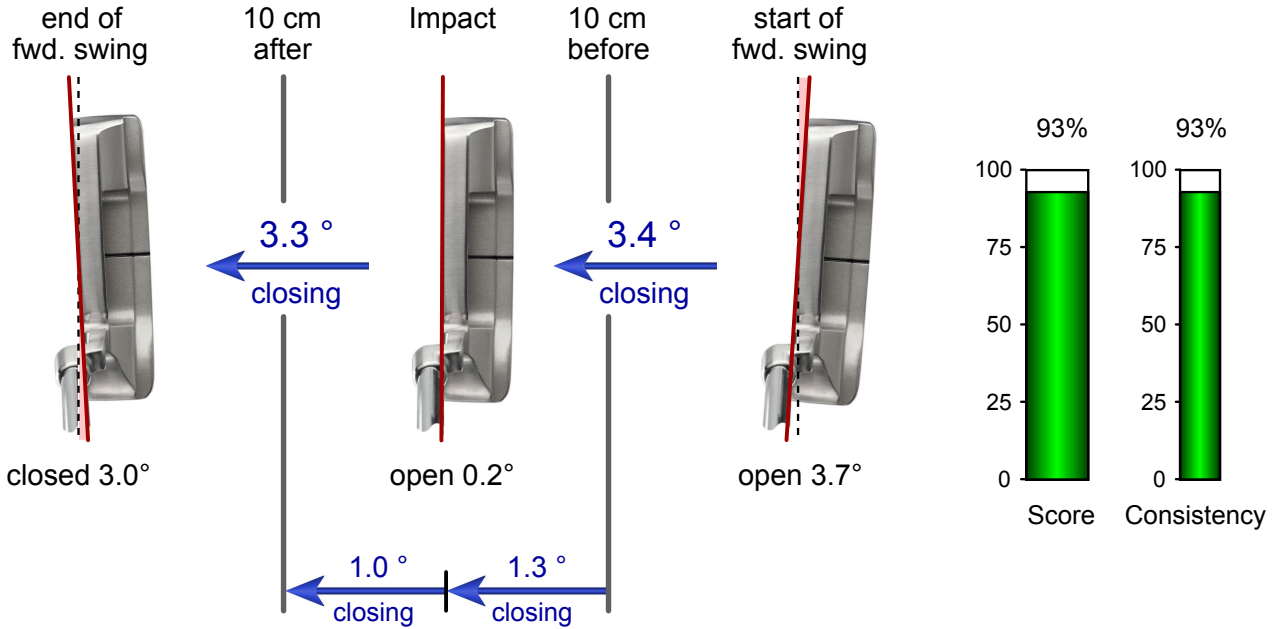

Rotation

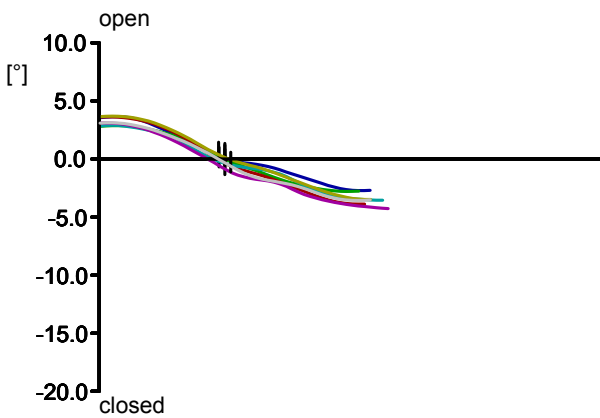

Rate of Rotation

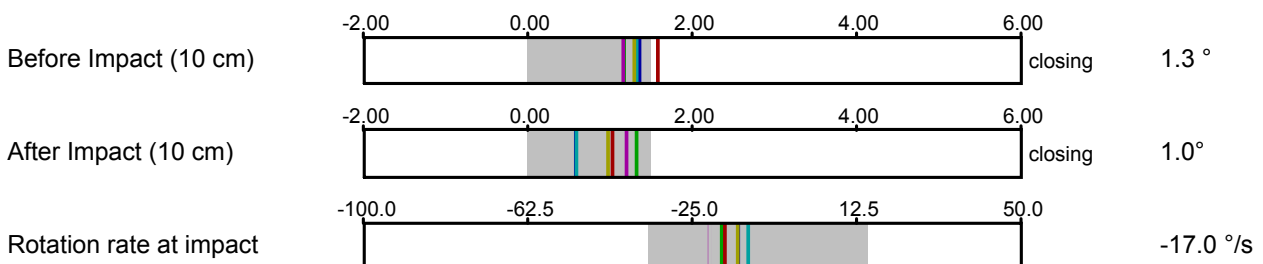
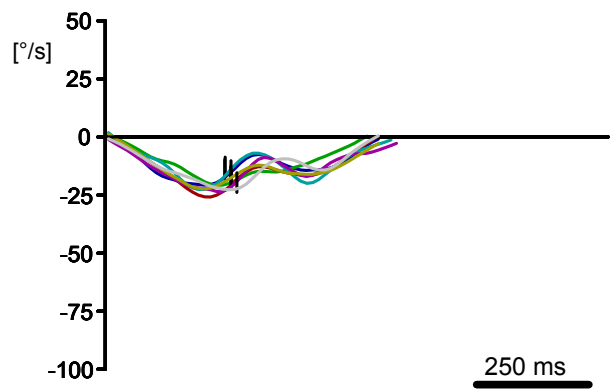



Project: Bay Of Plenty Golf
Player: Smith, Mark
File: 3rd measurement report Oct 06
Date: 14.10.2006

Movement Dynamics

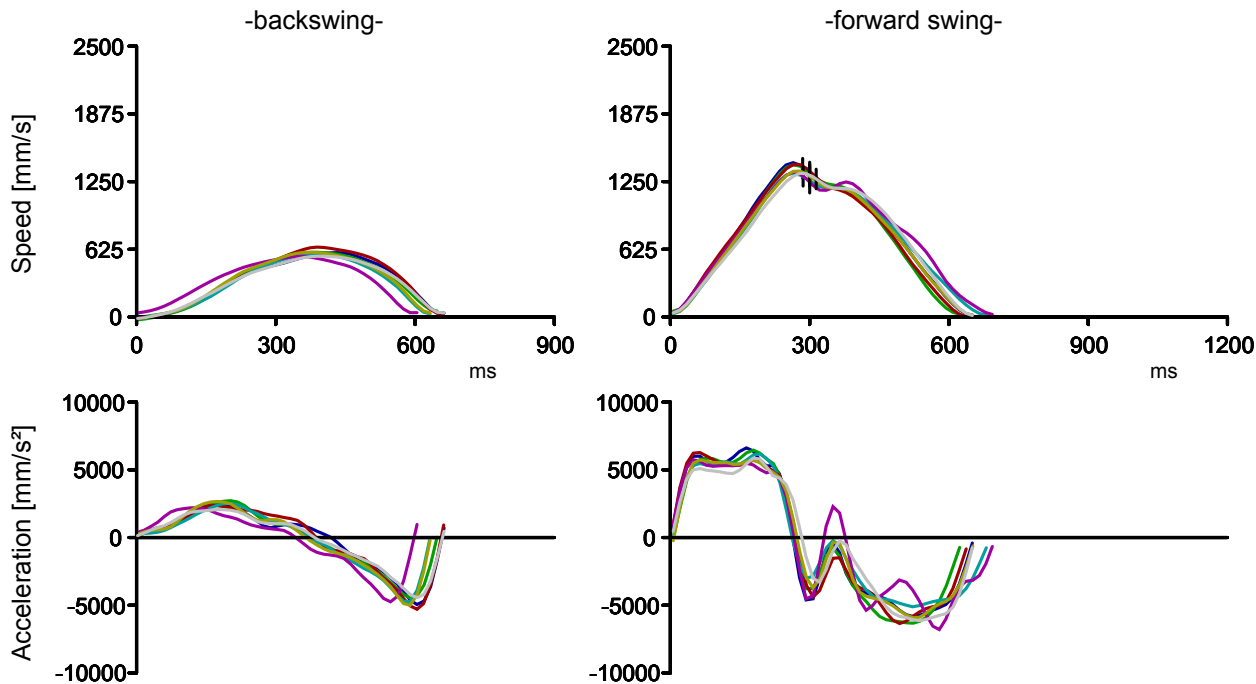

Timing

